

# INFRARED BASED PET CRYSTALLIZER



In Association with SVCH-Technologii, Moscow (Russia)  
ISO 9001:2015 | ISO 14001:2015 | ISO 45001:2018

# ABOUT US

KERONE is now renowned for serving the specialized needs of customers with the best quality and economical process of Heating /cooling and drying products, manufactured in a high-quality environment by a trained and qualified workforce (special purpose machinery)

-  48+ Years Manufacturing Excellence
-  Great Sale Support
-  Highly Customized Product
-  Adherence to Standards
-  Sound Infrastructure
-  Team of experts Delivering Quality
-  Timely Delivery
-  Cost Effective Solutions



KERONE is a pioneer in application and implementation engineering with its vast experience and team of professionals.



KERONE is devoteded to serve the industry to optimize its operations both economically and environmentally with its specialized heating and drying solutions.



KERONE is having immense expertise in manufacturing and implementing various types of engineering solutions.



KERONE is possessing employee strength of more than 280+ experts continuously putting efforts for happy industrial engineering solutions.

# WHY CHOOSE US

With decades of expertise, cutting-edge technology, and a customer-centric approach, Kerone Engineering offers tailor-made heating solutions that prioritize quality, flexibility, and cost-effectiveness. Benefit from our commitment to excellence, post-sales support, and innovative solutions for your unique heating needs. Choose Kerone Engineering for reliability, performance, and unmatched value.

## MISSION

- ✓ To enhance the value of customer operation through our customer need centric engineering solution
- ✓ We are committed to provide our customers, unique and best in class products in Industrial heating drying and cooling segment with strategic tie-up for the technical know-how with renowned leader in the industry specific segment

## VISION

- ✓ Turn into a world leader in providing specialized, top-notch quality and ecological industrial heating, cooling, and drying solutions across the globe.
- ✓ To attain global recognition as the best of quality and environment-friendly engineering solution company.

“

Enhance the value of customer operation through our customer need centric engineering solution.

”



## Introduction

An infrared-based PET crystallizer is an innovative technology designed to enhance the crystallization process of polyethylene terephthalate (PET), commonly used in manufacturing plastic bottles, containers, and synthetic fibers. PET crystallization is a critical step in PET recycling and production, as it improves the polymer's thermal stability, clarity, and mechanical properties. Traditional crystallization methods, often relying on convection heating, can be energy-intensive and time-consuming. Infrared-based crystallization, however, uses infrared radiation to directly heat the PET particles, resulting in faster and more uniform crystallization. This method can significantly reduce energy consumption, increase efficiency, and improve product quality, making it an attractive choice for industries seeking sustainable and cost-effective solutions.

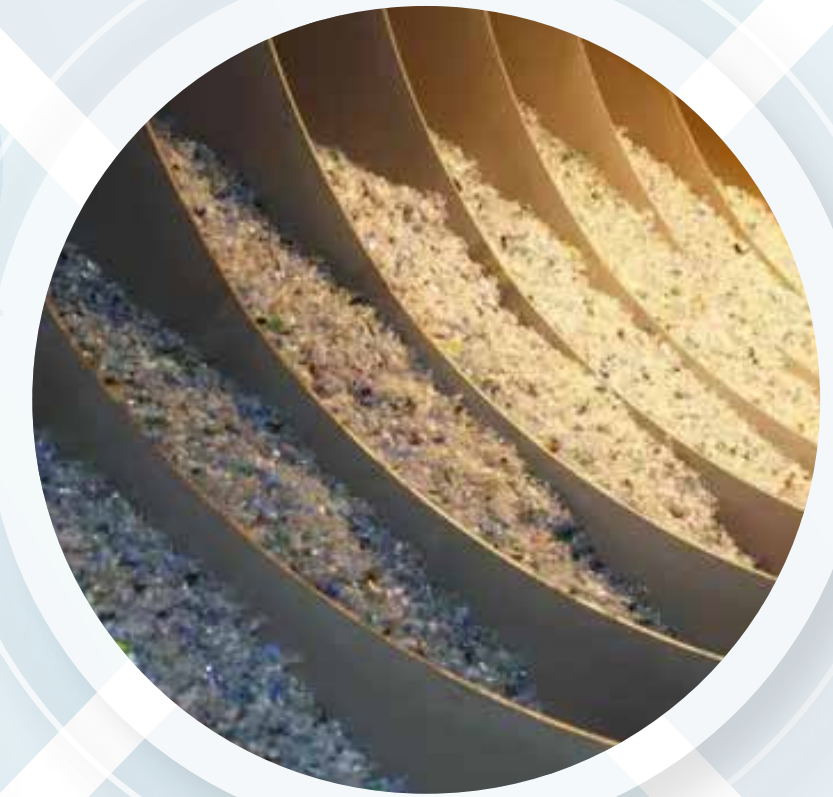

## Introduction of Infrared

- Infrared Heating System are part of Electromagnetic heating family.
- Infrared heater uses IR radiation waves falls just below visible light spectrum.
- Infrared radiator heat produce heat on the surface of material.
- Heat is transferred from outer surface to inner body.
- Infrared heating system produce heat same as 'SUN' from hot surface to cold surface.

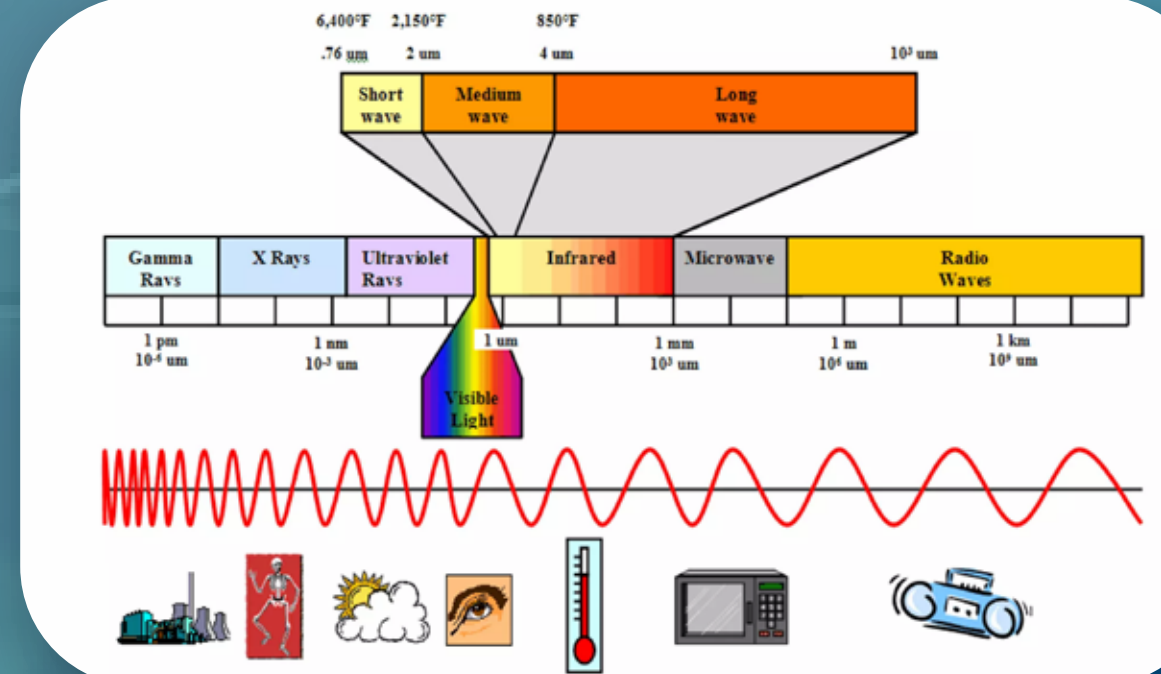

The electromagnetic spectrum describes the various types of electromagnetic energy best on wavelength

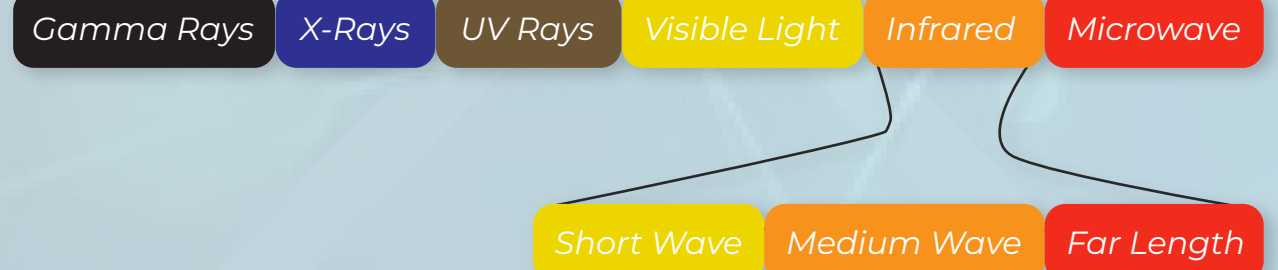

**Infrared Heating System are basically classified based on its emitting wave length :**

Far Infrared (3000 nm and Above)

Medium Wave (1400 nm and 3000 nm)

Short Wave (780 nm to 1400 nm)

# Infrared Based PET Crystallizer

## Working Principle

### Input

Calcium carbonate powder are fed into Kerone's advanced sensor based feed mechanism that ensures continues supply of adequate quantity only within the IR dryer

### Transport

Calcium carbonate powder to be dried are transported through the surface of rotary drum using internal helix

### Exposure

The drum is fitted in such as manner to get the maximum and equal IR exposure to each-Calcium carbonate powder.

### Heating

IR lamps produce the infrared wave that produces the heat when it strikes the material

### Drying

IR rays penetrates within the Calcium carbonate powder and starts removing moisture from inside-out

### Moisture removal

Moisture gets out of the flake and are removed from drum with flow of air

### Output

Calcium carbonate powder transported to output chamber and collected there.



## Control

Entire process is monitored and controlled by very easy to understand and highly sophisticated control mechanism with LCD screen and touch based control



# Infrared Based PET Crystallizer

## Schematic

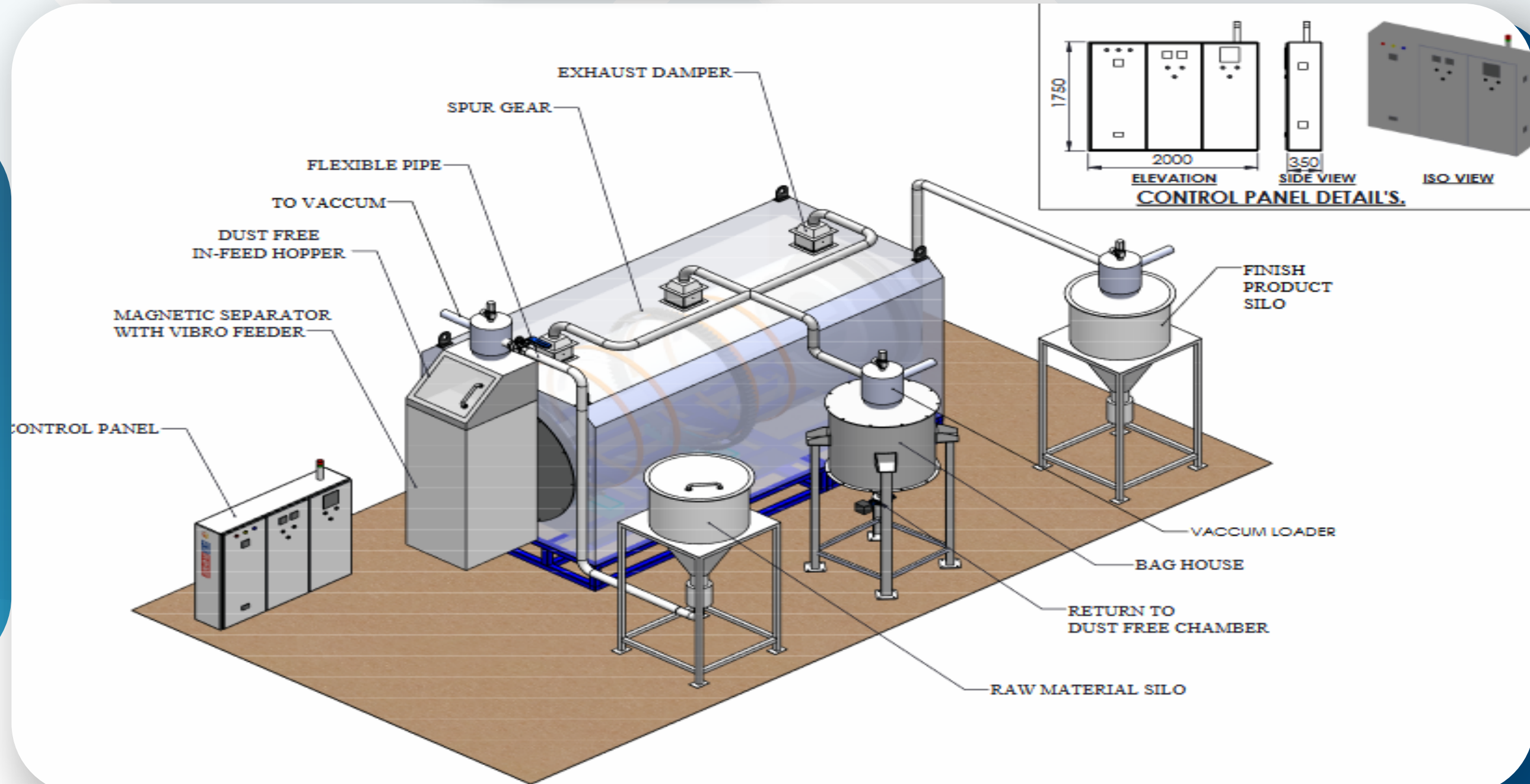

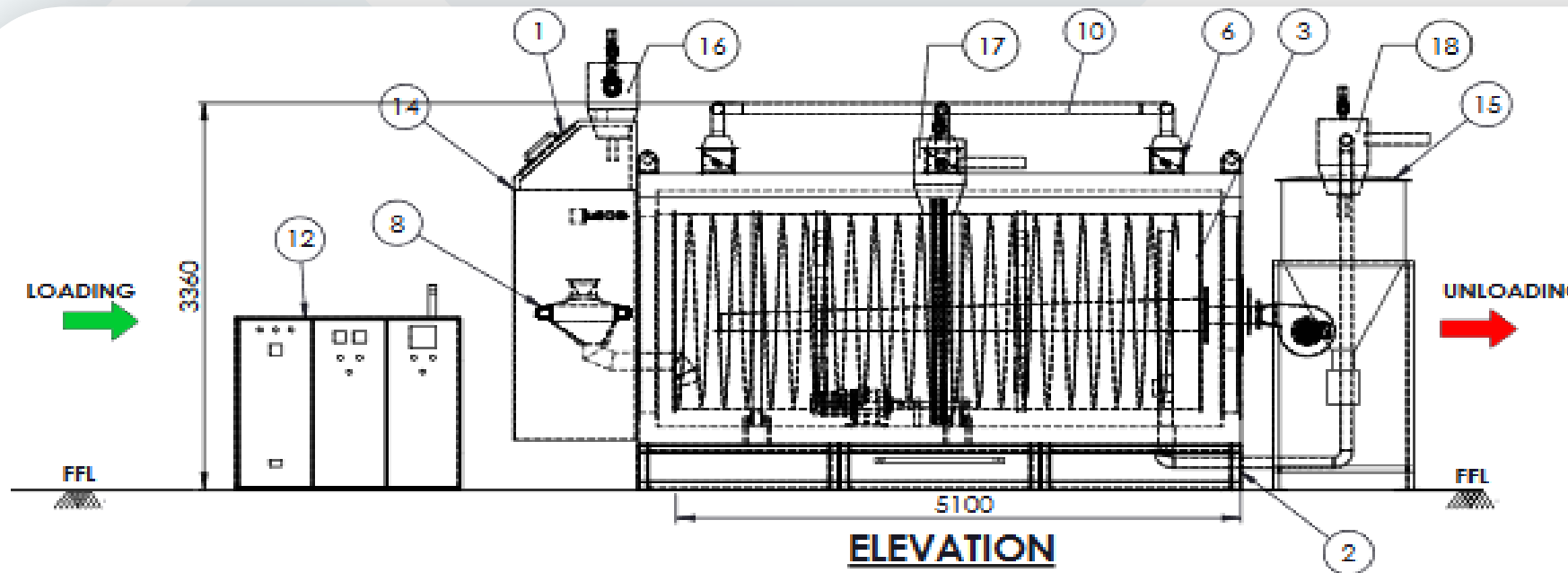

SR.NO	DESCRIPTION	REMARK	QTY
1	HOPPER WITH VIBROMOTOR	SS304	1
2	SUPPORT STRUCTURE	MS PAINTED	-
3	ROTARY DRUM	SS304	1
4	SPLR GEAR	MS	-
5	GEAR MOTOR DRIVE	REPUTED MAKE	1
6	EXHAUST DAMPER	MS PAINTED	2
7	BAG-HOUSE	MS PAINTED	1
8	VIBRO FEED MOTOR	CASTED	2
9	SLOWER	MS PAINTED	1
10	DUCTS	MS PAINTED	1
11	IR HEATERS	QUARTZ INFRARED	-
12	CONTROL PANEL	MS POWDER COATED	1
13	RAW MATERIAL SILO	MS PAINTED	1
14	MAGNETIC SEPARATOR	MS PAINTED	1
15	FINISH MATERIAL SILO	MS PAINTED	1
16	VACUUM LOADER 1	SS 304	1
17	VACUUM LOADER 2	SS 304	1
18	VACUUM LOADER 3	SS 304	1

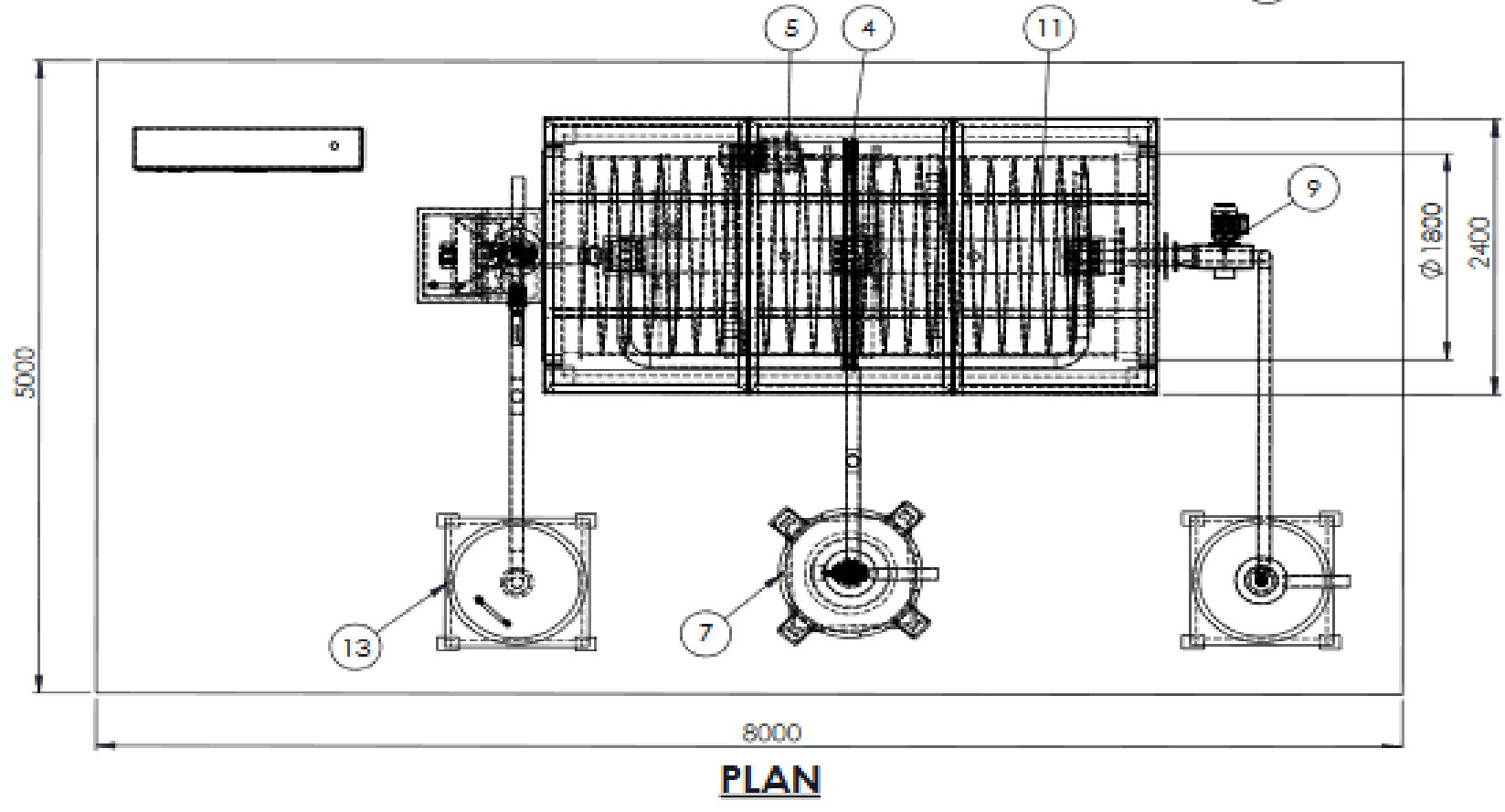

**PLAN**

# Infrared Based PET Crystallizer

## Features



### One Step Process

IR based systems are capable of crystallizing and/or drying up to 33000 lb/hr (15000 Kg/hr) in single stroke

### Energy Savings

IR crystallizers/ dryers provide energy saving of up to 45% as it dries in single run and in minimum time

### Quick Change over

Unlike conventional systems it does not requires 5-6hrs for processing. Drying takes place within one hour only.

### Less floor area consumption

IR systems offers upto 400% space saving less in-process inventory and smaller footprint

### Digitally controlled

100% digital control mechanism, quick start and stop

### 4-5 times faster than conventional System

IR systems reduces moisture from over 3500 ppm to less than 50 ppm in about an hour.

Conventional systems requires 5-6 hrs

## Infrared Dryer Myths

### Myth

Infrared rays destroy the IV properties of PET flake

### Realty

Shorter exposure to heat in IR dryer helps in preserving the properties

### Myth

Installation Cost of IR dryers are huge compared to Conventional

### Realty

Initial costs of IR dryers are marginally high but profitable in long run compared to Conventional

### Myth

IR technology is only applicable on low throughput applications

### Realty

IR dryers are capable of drying over 4,000 lb/hr.

### Myth

IR is new and maintenance cost is high

### Realty

More than 100 are running successfully and maintained efficiently

### Myth

Application is limited to Salt only

### Realty

Kerone has provided the IR systems for more huge type of applications

### Myth

IR dryers can reduce the moisture only up to 50ppm

### Realty

Moisture level of less than 50 ppm is reached in just one hour and the moisture content can be controlled to higher levels if required

## Infrared Heating System *Vs*

## Conventional Heating System

| IR heating system are fast heating system, result in saving of time.

| Instant heating of the material, hence no warm up time.

| Environmental friendly and green heating solution, no carbon emission.

| 100% energy utilization, Heats only desired spot of material.

| Better floor utilization index.

No Temperature loss in surrounding, ambient workplace.

| Conventional heaters have slow heating rate, heat is transferred via means of air.

| Instance heating does not takes place, it requires warm-up of surrounding.

| Produces carbon or toxic gases hence not much environmental friendly heating solutions.

| 100% energy utilization is not possible, as material is heated by surrounding hot air.

| Poor floor utilization index.

Surrounding air temperature rises with rise in heater temperature.

# TRUSTED PARTNERS

**AFCONS**

**Technip**

**TÜV**

ISO 14001:2004

**TOYO**  
ENGINEERING

**EIL**

**LLOYD'S**

**ZEPPELIN**  
WE CREATE SOLUTIONS

**Reliance**  
Engineering  
Associates Pvt. Ltd.

**TATA**  
TATA CONSULTING ENGINEERS LIMITED

**SC Shroff** Consultants

**STERLING & WILSON**

# THANK YOU

## UNIT I

📍 4 & 5, Marudhar Industrial Estate, Panchal Road, Opp. Syndicate Bank, Bhayander (E), Mumbai-401105. (India)

📞 Contact Us  
+91-22 48255071, 48255072

## UNIT II

📍 Kerone Engineering Solutions LTD., Plot No. B-47, Addl. Midc Anandnagar, Ambernath (E), Dist. Thane (India)- 421506

📞 Contact Us  
+91(0251)2620542/43/44/45/46

### ✉ Our Mails

[info@kerone.com](mailto:info@kerone.com)

[sales@kerone.com](mailto:sales@kerone.com)

[marketing@kerone.com](mailto:marketing@kerone.com)

### 🌐 Website

[www.kerone.com](http://www.kerone.com)

[www.kerone.net](http://www.kerone.net)

[www.keroneindia.com](http://www.keroneindia.com)



SCAN HERE

